



# Choice Bagging Equipment, Ltd.

*Industrial Bag Packaging Equipment, Systems, Support, & Service*

## 800 Series Paddle Flow Vertical Impeller Valve Bag Filler

### Unit Description:

Vertical Style Impeller Valve Bag Filler for Packaging 20-110 lbs (9-50KG) Bags with Fine Powders of Mid-Range to High Bulk Density at a Rate of up to 12 Bags / Minute

### Examples of Proper Application Include:

- Portland Cement, Mortar Mixes, Stucco, Grout
- Gypsum, Barite

### Technical Specifications:

- Proper Application – Mid to High Bulk Density Powders (50-100 lbs / Cu Ft)
- Weight Range – 20-110 lb. (9-50KG) Valve Bags
- Fill Rate – 1-12 Bags Per Minute (Depending on Product Characteristics & Bag Sizing)
- Typical Scale Weight Accuracy - +/- .5-1% of Target Weight (Depending on Product Characteristics, Bag Sizing and Options Selected)
- Control Air – 80 PSI Required @ 1 CFM Per Bag Fill Cycle  
Electrical – 220/440 Volt / 3 Ph / 60 Cycle (Step Down Transformer for 110V Control Voltage Included)
- Dust Collection – 600 CFM Minimum

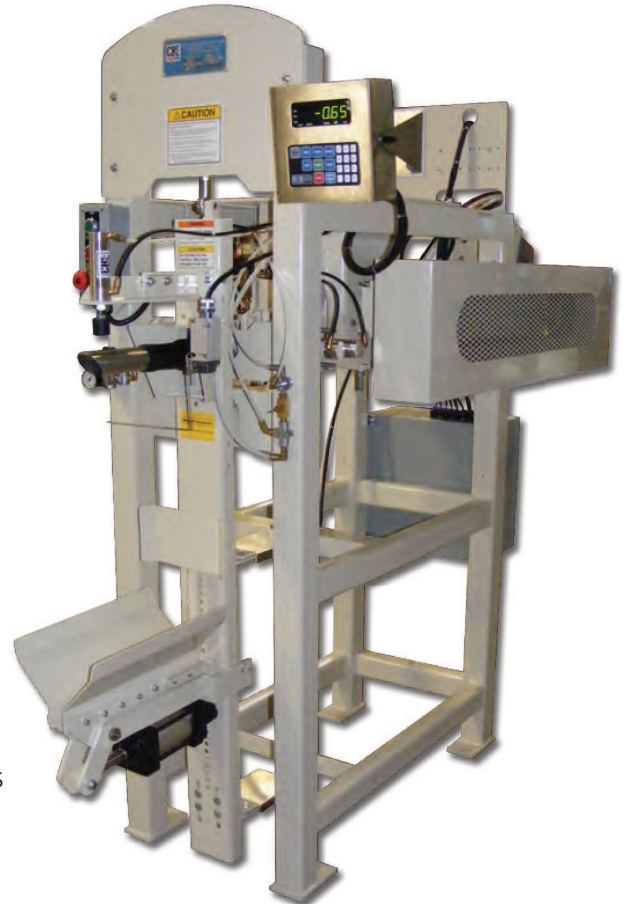

*NOTE: Product testing may be required to determine actual bag filling rates and bag weight accuracy.*

### Principle Of Operation:

The 800 Series has a specially Designed Vertical 4 blade impeller powered by a horizontal drive shaft. Product flows by gravity from the supply hopper into the product feed inlet at the top of the machine. When a fill cycle is initiated, the product is conveyed by opposing twin feed screws into the impeller which conveys the product into the bag.

### Clean Operation:

The Model 800 Series has a totally enclosed product flow path from supply hopper all the way into the bag. It can also be equipped with our 112 dust collection manifold which can be ducted to your plants dust suppression system. Together with our optional 111 Tube Cleanout, 117 Expanding Bag Seal Assemblies and a filling spout arrangement that is appropriately designed for your application, the 800 Series is the cleanest filling impeller style valve bag filler available on the market.

Visit [choicebagging.com](http://choicebagging.com) or call 512.352.3694 for more info!

# 800 Series Paddle Flow Vertical Impeller Valve Bag Filler

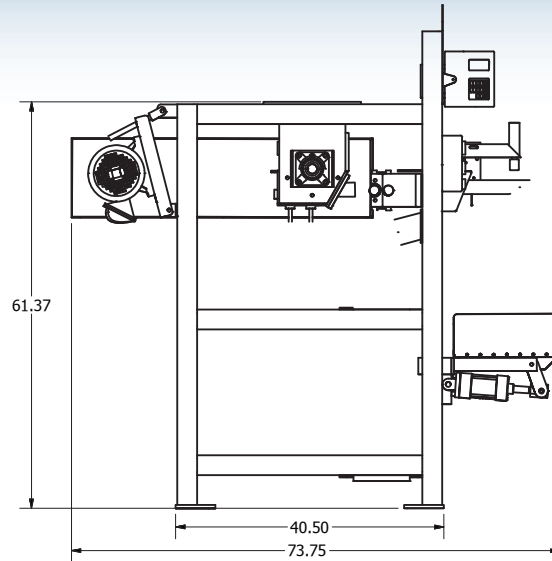
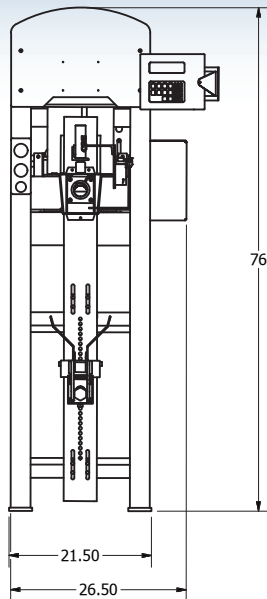

## STANDARD FEATURES

- Mild Steel Contacting Surfaces
- Digital Load Cell Weighing
- Scale Isolator Assembly
- 3" X 3" Tubular Steel Framework
- 4-Blade Impeller
- 7.5 HP Belt Drive Assembly
- Manual Start/Stop Push Buttons
- Air Operated Bag Clamp & Pinch Tube Material Cutoff
- Adjustable Bag Rest
- 1.5" -2.75" Single Wall Fill Spout (Sized per Customer Requirements)

## STANDARD OPTIONS

- 106-300 – Air Actuated Powered Tilt Bag Rest
- 103-300 – Bulk & Dribble (Two-Stage) Cutoff (Must Be Used w/ Option 104-002)
- 111-100 – Tube Cleanout Assembly (Must Be Used w/ Option 104-002)
- 112-100 – Dust Collection Pickup Manifold
- 115-100 – Auto Start Assembly
- 117-000 – Timed Bag Seal Assembly
- 801-000 – Twin Feed Screws for Increased Product Flow & Feed to Impeller
- 820-000 – 304 S/S Material Contacting Surfaces
- HF – Hard Faced Impeller

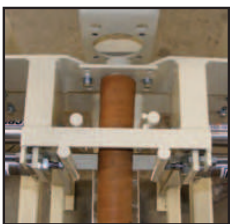

Bulk & Dribble Cutoff



Powered Bag Chair



Tapered Cone



Timed Bag Seal



Impeller Feeder

**Experience. Quality. Service.**

Visit [choicebagging.com](http://choicebagging.com) or call 512.352.3694 for more info!