



Choice Bagging Equipment, Ltd.

Industrial Bag Packaging Equipment, Systems, Support, & Service

700 Series Pressure Flow Pneumatic Valve Bag Filler

Unit Description:

Pneumatic (Air) Style Valve Bag Filler for Packaging 20-110 lbs (9-50KG) Bags With Positive Flow Characteristics Such as Flaked, Powdery and/or Granular Products at a Rate of Up to 12 Bags/Minute.

Examples of Proper Application Include:

- Concrete, Stucco, Grout, Sand & Refractory Materials
- Bentonite, TIO₂, Iron Oxide, Carbon Black
- Plastic Pellets, Fertilizer, Seeds

Technical Specifications:

- Proper Application – Powders, Pellets, & Granules
- Weight Range – 20-110 lb. (9-50KG) Valve Bags
- Fill Rate – Up to 12 Bags per Minute (Depending on Product Characteristics & Bag Sizing)
- Typical Scale Weight Accuracy – +/- .5-1% of Target Weight (Depending on Product Characteristics, Bag Sizing and Options Selected)
- Control Air – 80 PSI Required @ 1 CFM Per Bag Fill Cycle
- Electrical – 110 Volt / 3 PH / 60 Cycle
- Dust Collection – 600 CFM Minimum



NOTE: Product testing may be required to determine actual bag filling rates and bag weight accuracy.

Principle Of Operation:

The 700 series air packer has a specially designed fluidizing air slide powered by an external source of low pressure, high volume air. Product flows by gravity from the supply hopper bin into the product feed inlet at the top of the machine. When a fill cycle is initiated, the product is fluidized by the air slide. The 700 series is an automatic electronic scale gross weighing filler that simultaneously fills and weighs product directly into the bag.

Clean Operation:

The 700 series air packer has a totally enclosed product flow path from supply hopper all the way into the bag. It can also be equipped with our 112-100 dust collection manifold which can be ducted to your plants dust suppression system. Together with our optional 111 Tube Cleanout, 117 Expanding Bag Seal Assemblies and a filling spout arrangement that is appropriately designed for your application, the 700 is the cleanest filling pneumatic (air) style valve bag filler available on the market.

Visit choicebagging.com or call 512.352.3694 for more info!

700 Series Pressure Flow Pneumatic Valve Bag Filler

STANDARD FEATURES

- Mild Steel Contacting Surfaces
- Digital Scale Weighing
- Scale Isolator Assembly
- 3" X 3" Tubular Steel Framework
- Manual Start / Stop Push Buttons
- Air Operated Bag Clamp & Pinch Tube Material Cutoff
- Adjustable Bag Rest
- 1.5" -2.75" Single Wall Fill Spout (Sized per Customer Requirements)
- 3 Cubic Foot Upper Pressurizing Chamber w/ 12" -Butterfly Material Inlet Valve
- 8" X 14" Rectangular Sight Glass Window

STANDARD OPTIONS

- 106-300 – Air Actuated Powered Tilt Bag Rest
- 103-300 – Bulk & Dribble (Two-Stage) Cutoff (Must Be Used w/ Option 104-002)
- 111-100 – Tube Cleanout Assembly (Must Be Used w/ Option 104-002)
- 112-100 – Dust Collection Pickup Manifold
- 115-100 – Auto Start Assembly
- 116-000 – Tapered Cone
- 117-000 – Timed Bag Seal Assembly

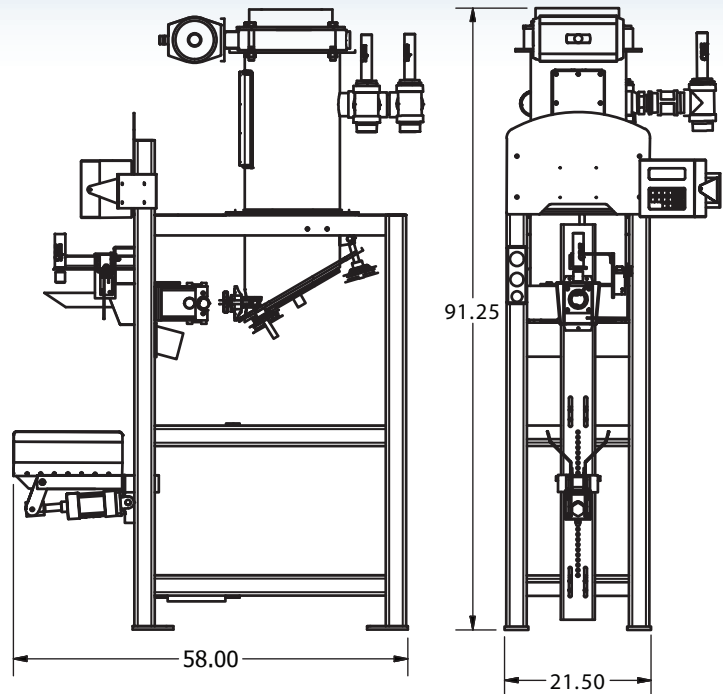

- 708-306 – Low Pressure Blower Package (For Light Bulk Density Products & Atmospherics)
- 708-405 – Low Pressure Blower Package (For Medium Bulk Density Products (40-80 lbs Cu Ft))
- 708-503 – Low Pressure Blower Package (For Heavy Bulk Density Products (80 lbs Cu Ft +))
- 709-100 – Plug Stack Inlet (Recommended for Abrasive & Non-Compressible Products)
- 720-000 – 304 S/S Material Contacting Surfaces

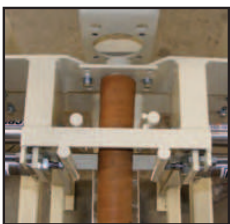

Bulk & Dribble Cutoff



Powered Bag Chair



Timed Bag Seal



Plug Stack Inlet



Low Pressure Blower

Experience. Quality. Service.

Visit choicebagging.com or call 512.352.3694 for more info!