



Choice Bagging Equipment, Ltd.

Industrial Bag Packaging Equipment, Systems, Support, & Service

200 Series Spiral Flow Auger Valve Bag Filler

Unit Description:

Auger Style Valve Bag Filler for Packaging 20-110 lbs (9-50KG) Bags with Hard-to-Handle Powders, Flakes & Granules at a Rate of up to 6 Bags/Minute.

Examples of Proper Application Include:

- Cocoa, Flour, Black Pepper
- Pigments, Organic & Chemical Resins
- Cement, Plaster

Technical Specifications:

- Proper Application — Flakes, Fibers & High Density Powders
- Weight Range — 20-110 lb. (9-50KG) Valve Bags
- Fill Rate — 1-6 Bags Per Minute (Depending on Product Characteristics & Bag Sizing)
- Typical Scale Weight Accuracy — +/- .5-1% of Target Weight (Depending on Product Characteristics, Bag Sizing and Options Selected)
- Control Air — 80 PSI Required @ 1 CFM Per Bag Fill Cycle (Base Model Does not Require Air)
- Electrical — 20/440 Volt / 3 Ph / 60 Cycle (Step Down Transformer for 110V Control Voltage Included)
- Dust Collection — 400 CFM

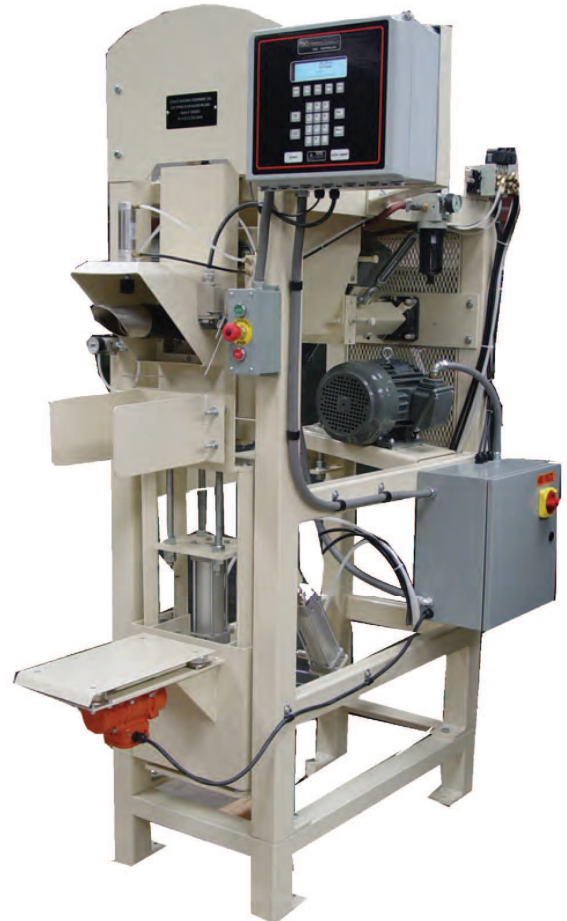

NOTE: Product testing may be required to determine actual bag filling rates and bag weight accuracy.

Principle Of Operation:

The 200 Series auger packer has a specially designed horizontal screw auger powered by a horizontal drive shaft. Product flows by gravity from the supply hopper bin into the product feed inlet at the top of the machine. When a fill cycle is initiated, the product is conveyed by the auger into the bag. The 200 Series is an automatic electronic scale gross weighing filler that simultaneously fills and weighs product directly into the bag.

Clean Operation:

The 200 Series auger packer has a totally enclosed product flow path from the supply hopper bin all the way into the bag. It is also equipped standard with a built-in dust collection manifold which can be ducted to your plants dust suppression system. Coupled with our optional 117-000 Expanding Bag Seal Assembly, the 200 is the cleanest filling horizontal auger style valve bag filler on the market.

Visit choicebagging.com or call 512.352.3694 for more info!

200 Series Spiral Flow Auger Valve Bag Filler

STANDARD FEATURES

- Mild Steel Contacting Surfaces
- Digital Load Cell Weighing
- 3" X 3" Tubular Steel Framework
- 5 HP Belt Drive Assembly
- Manual Start / Stop Push Buttons
- Manual Bag Clamp
- Adjustable Bag Rest
- 2.5" -3.5" Single Wall Fill Spout
(Sized per Customer Requirements)
- Single Speed Motor Controls (220/440V)

STANDARD OPTIONS

- 101-500 —Air Operated Bag Clamp
- 101-600 —Caster Mobility Assembly
- 106-300 —Air Actuated Powered Tilt Bag Rest
- 106-400 —Vibratory Settling Bag Rest Assembly
- 109-505 —Variable Bulk & Dribble Filling Speeds (240V)
- 109-506 —Variable Bulk & Dribble Filling Speeds (480V)
- 112-200 —Dust Collection Pickup Manifold
- 113-000 —Drum Filling Attachment
- 115-100 —Auto Start Assembly (Electronic)
- 117-000 —Timed Bag Seal Circuit
- 220-000 —304 S/S Material Contacting Surfaces
- 204-000 —Bridge Breaker Agitator Assembly
- 207-000 —Dust Tight Air Operated Open Mouth Bag Filling Attachment (M/S)

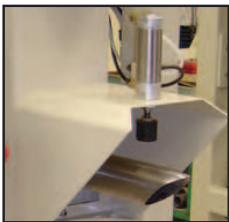
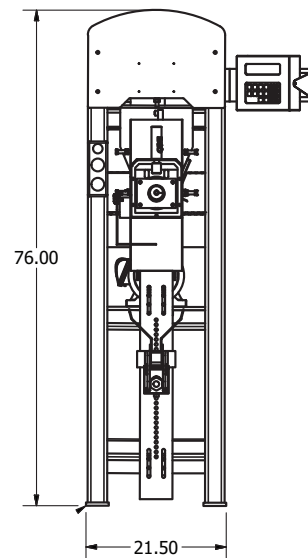
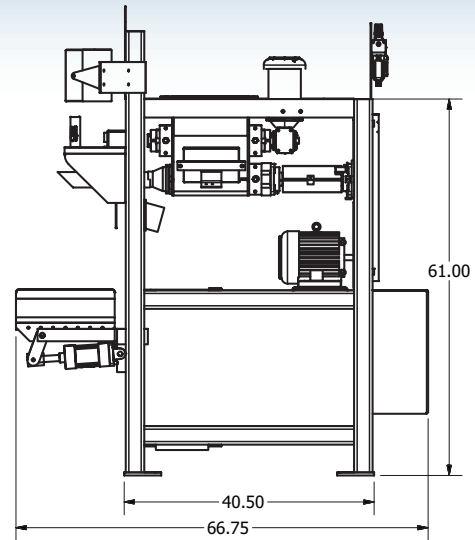

Air Operated Bag Clamp



Drum Filling Attachment



Agitator Assembly



Open Mouth Attachment



Drop Bottom Housing

Experience. Quality. Service.

Visit choicebagging.com or call 512.352.3694 for more info!